



SF201G THRU SF207G

Glass Passivated Super Fast Recovery Rectifier

Features

- * Fast switching for high efficiency
- * Low forward voltage drop
- * High current capability
- * Low reverse leakage current
- * High surge current capability

Mechanical Data

- * Case: Molded plastic, DO-15
- * Epoxy: UL 94V-0 rate flame retardant
- * Terminals: Solderable per MIL-STD-202, method 208
- * Polarity: Color band denotes cathode end
- * Mounting position: Any

Voltage Range 50 to 800 V
Current 2.0 Ampere

DO-15

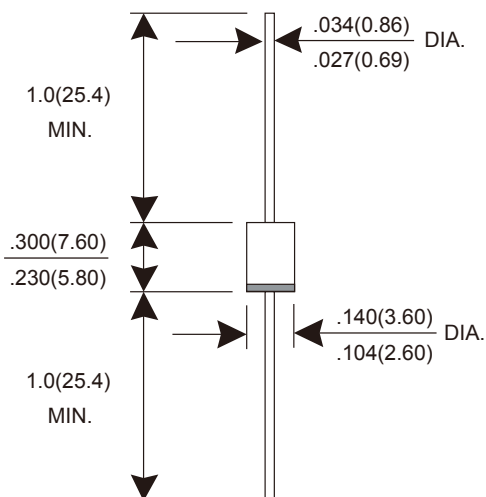

Dimensions in inches and (millimeters)

MAXIMUM RATINGS AND ELECTRICAL CHARACTERISTICS

Rating at 25°C ambient temperature unless otherwise specified.

Single phase, half wave, 60Hz, resistive or inductive load.

For capacitive load, derate current by 20%.

PARAMETER	SYMBOL	SF 201G	SF 202G	SF 203G	SF 204G	SF 205G	SF 206G	SF 207G	UNIT
Maximum repetitive peak reverse voltage	V_{RRM}	50	100	200	300	400	600	800	V
Maximum RMS voltage	V_{RMS}	35	70	140	210	280	420	560	V
Maximum DC blocking voltage	V_{DC}	50	100	200	300	400	600	800	V
Maximum average forward rectified current @ $T_A=55^\circ\text{C}$	$I_{F(AV)}$	2.0							A
Peak forward surge current 8.3 ms single half sine-wave superimposed on rated load	I_{FSM}	50							A
Maximum instantaneous forward voltage @ $I_F=2.0\text{A}$	V_F	0.95		1.3		1.7		V	
Maximum DC reverse current at rated DC blocking voltage @ $T_A=25^\circ\text{C}$ @ $T_A=125^\circ\text{C}$	I_R	1 150							μA
Maximum reverse recovery time (Note 1)	t_{rr}	35							ns
Typical junction capacitance (Note 2)	C_J	50			30			pF	
Typical thermal resistance from junction to ambient (Note 3)	$R_{\theta JA}$	40							$^\circ\text{C/W}$
Operating junction and storage temperature range	T_J, T_{STG}	-55 to +150							$^\circ\text{C}$

NOTES : (1) Reverse recovery test conditions $I_F = 0.5\text{A}$, $I_R = 1.0\text{A}$, $I_{rr} = 0.25\text{A}$.

(2) Measured at 1.0 MHz and applied reverse voltage of 4.0 Volts DC.

(3) Thermal resistance from junction to ambient at 0.375" (9.5 mm) lead length, PCB mounted.

RATINGS AND CHARACTERISTICS CURVES SF201G THRU SF207G

Fig.1 - Forward Current Derating Curve

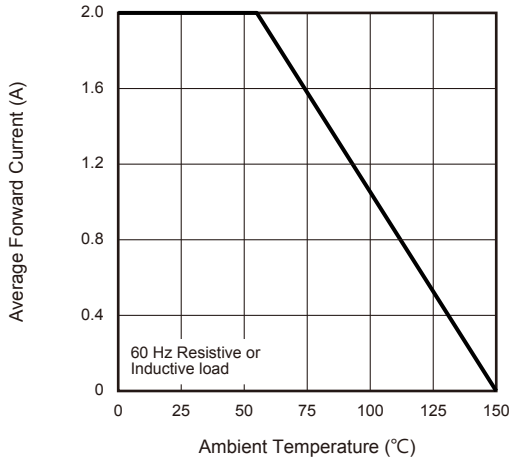

Fig.2 - Maximum Non-Repetitive Peak Forward Surge Current

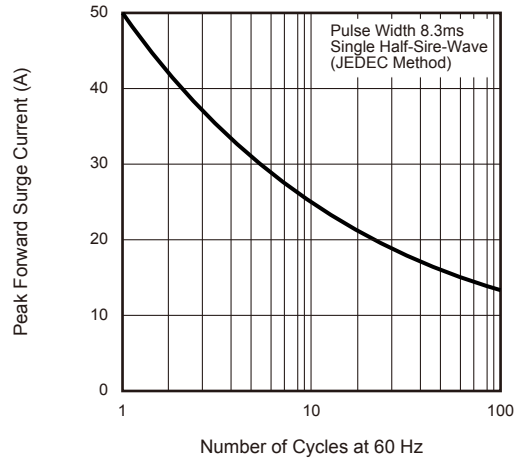

Fig.3 - Typical Instantaneous Forward Characteristics

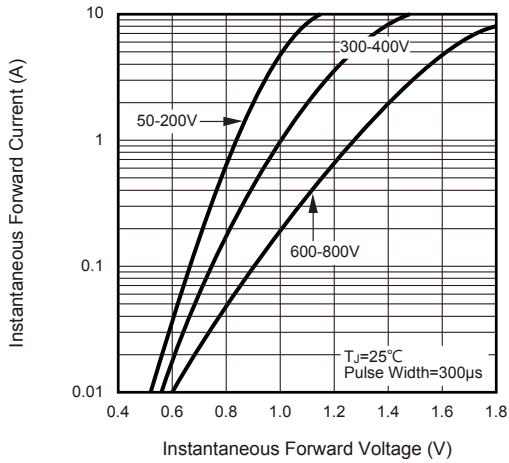

Fig.4 - Typical Reverse Leakage Characteristics

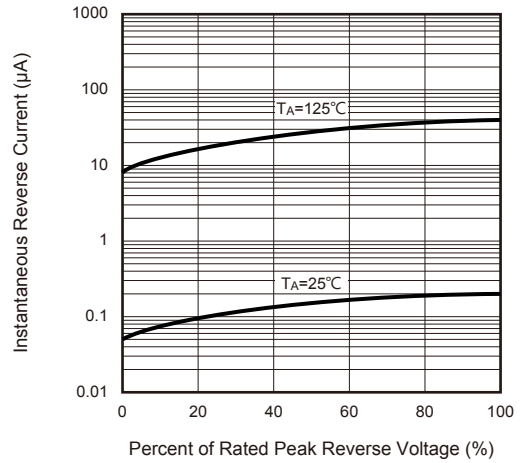

Fig.5 - Typical Junction Capacitance

