



2A01G THRU 2A07G

Glass Passivated Standard Rectifier

Features

- * Low forward voltage drop
- * High current capability
- * Low reverse leakage current
- * High surge current capability

Mechanical Data

- * Case: Molded plastic, DO-15
- * Epoxy: UL 94V-0 rate flame retardant
- * Terminals: Solderable per MIL-STD-202, method 208
- * Polarity: Color band denotes cathode end
- * Mounting position: Any

Voltage Range 50 to 1000 V
Current 2.0 Ampere

DO-15

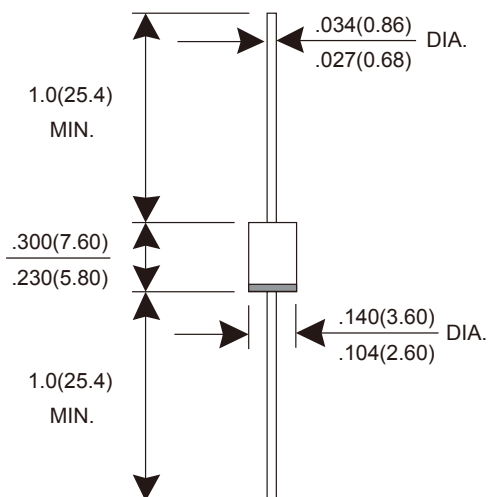

Dimensions in inches and (millimeters)

MAXIMUM RATINGS AND ELECTRICAL CHARACTERISTICS

Rating at 25°C ambient temperature unless otherwise specified.

Single phase, half wave, 60Hz, resistive or inductive load.

For capacitive load, derate current by 20%.

PARAMETER	SYMBOL	2A01G	2A02G	2A03G	2A04G	2A05G	2A06G	2A07G	UNIT
Maximum repetitive peak reverse voltage	V_{RRM}	50	100	200	400	600	800	1000	V
Maximum RMS voltage	V_{RMS}	35	70	140	280	420	560	700	V
Maximum DC blocking voltage	V_{DC}	50	100	200	400	600	800	1000	V
Maximum average forward rectified current @ $T_A=55^\circ\text{C}$	$I_{F(AV)}$	2.0							A
Peak forward surge current 8.3 ms single half sine-wave superimposed on rated load	I_{FSM}	70							A
Maximum instantaneous forward voltage @ $I_F=2\text{A}$	V_F	1.1							V
Maximum DC reverse current at rated DC blocking voltage @ $T_A=25^\circ\text{C}$ @ $T_A=125^\circ\text{C}$	I_R	5 100							μA
Typical junction capacitance (Note 1)	C_J	35							pF
Typical thermal resistance from junction to ambient (Note 2)	$R_{\theta JA}$	50							$^\circ\text{C}/\text{W}$
Operating junction and storage temperature range	T_J, T_{STG}	-55 to +150							$^\circ\text{C}$

Notes : (1) Measured at 1.0 MHz and applied reverse voltage of 4.0 Volts DC.

(2) Thermal resistance from junction to ambient at 0.375" (9.5 mm) lead length, PCB mounted.

RATINGS AND CHARACTERISTICS CURVES 2A01G THRU 2A07G

Fig.1 - Forward Current Derating Curve

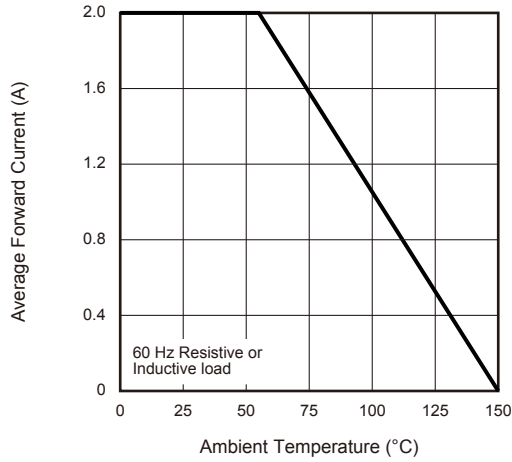

Fig.2 - Maximum Non-Repetitive Peak Forward Surge Current

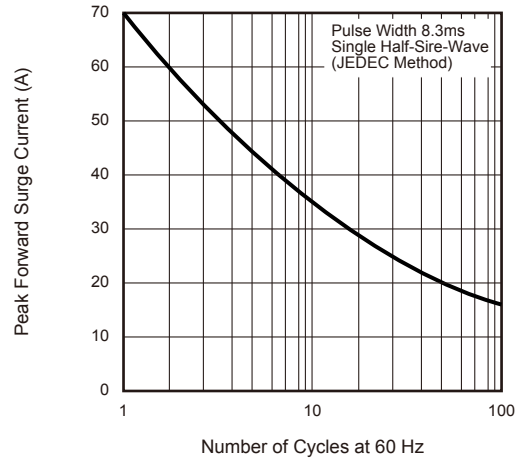

Fig.3 - Typical Instantaneous Forward Characteristics

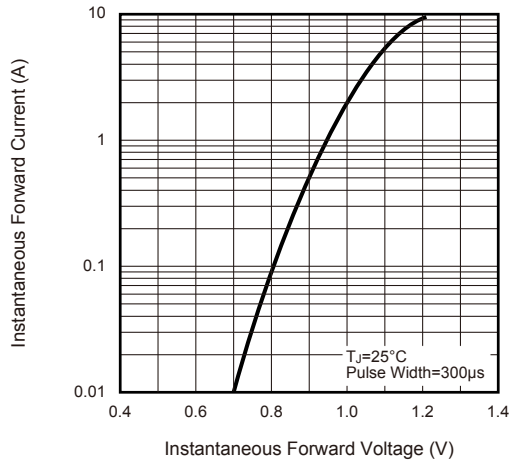

Fig.4 - Typical Reverse Leakage Characteristics

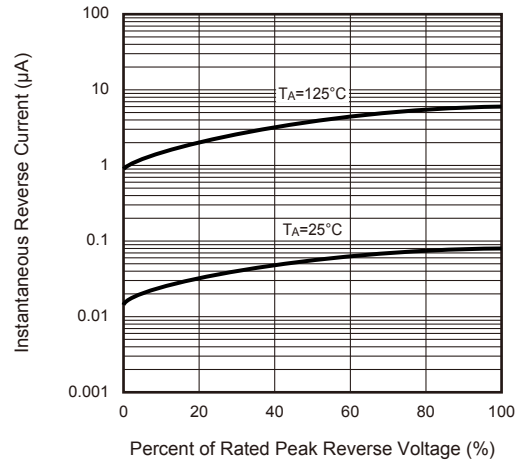

Fig.5 - Typical Junction Capacitance

